

© COPYRIGHT 19 78 BY AMP INCORPORATED, HARRISBURG, PA.  
ALL INTERNATIONAL RIGHTS RESERVED. AMP INCORPORATED PRODUCTS  
COVERED BY U. S. AND FOREIGN PATENTS AND/OR PATENTS PENDING.

REVISIONS						
P	F	ZONE	LTR	DESCRIPTION	DATE	APPROVED
✓			C	REV PER EC 0730-0201-94	4-26-95	JH RS
✓						
✓						

- ⚠ SHEET METAL SCREWS NOT SUPPLIED.
- ⚠ INSERT IS ATTACHED TO STRAIN RELIEF. AS AN ADDITIONAL ADJUSTMENT FOR SMALL WIRE BUNDLES, IT SHOULD BE CUT OFF AND POSITIONED AS SHOWN BY DOTTED LINES.
- ⚠ TWO REQUIRED PER CONNECTOR.
- 4. DETACHABLE INSERT MAY SEPARATE FROM STRAIN RELIEF BODY DURING SHIPPING.

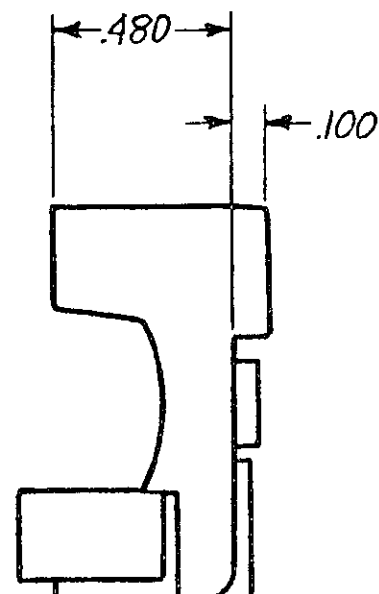
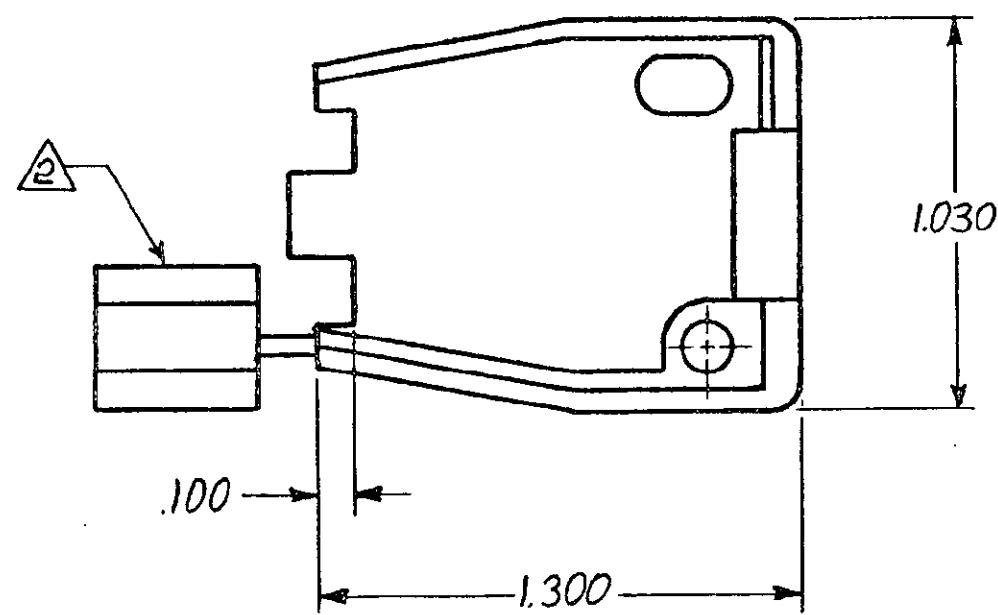

(2 REQ'D) #6 x .625 LG. TYPE "B" PAN HEAD SHEET METAL SCREWS ⚠

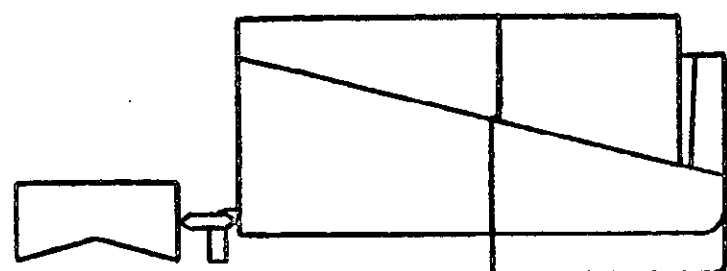
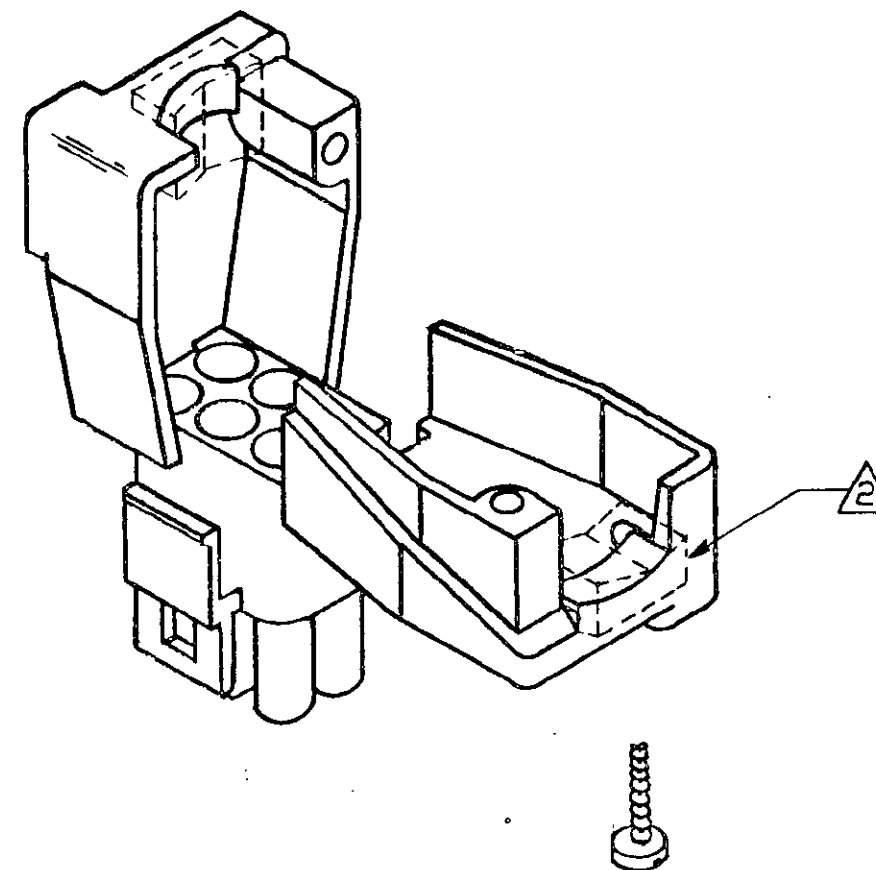

		NYLON 94V-0		640715-1	
		MATERIAL		PART NO	
WIRE BUNDLE DIA		UNLESS OTHERWISE SPECIFIED DIMENSIONS ARE IN INCHES.		CONTRACT NO	
WITHOUT INSERT	.650 MAX	TOLERANCES ON: DECIMALS ± .015 ANGLES ±		DR C. ERISMAN 10-2678	
WITH INSERT	.120 MIN	MATERIAL		CHK D.S. Heide 11/1/78	
		SEE TABLE		APPD J.C.M. 11-1-78	
		FINISH		APPD	
		SEE TABLE		DSGN APPD	
				OTHER APPD	
		AMP INCORPORATED Harrisburg, Pa.		NAME	
				STRAIN RELIEF AND INSERT, 6 CIRCUIT, UNIVERSAL MATE-N-LOK™	
		SIZE		CODE IDENT NO	
		C		00779	
		DRAWING NO		640715	
		SCALE		SHEET	
		NTS		1 OF 1	

640715

640715